

LENS - UNIVERSITA' DI FIRENZE -			
LARGO E. FERMI, 2 50125 FIRENZE			
Titolo	LASER DRIVER ASSEMBLY		
Size	Document Number	Rev	
A3	LASERDRV_1.SCH		
Date:	Friday, March 23, 2007	Sheet	2 of 2

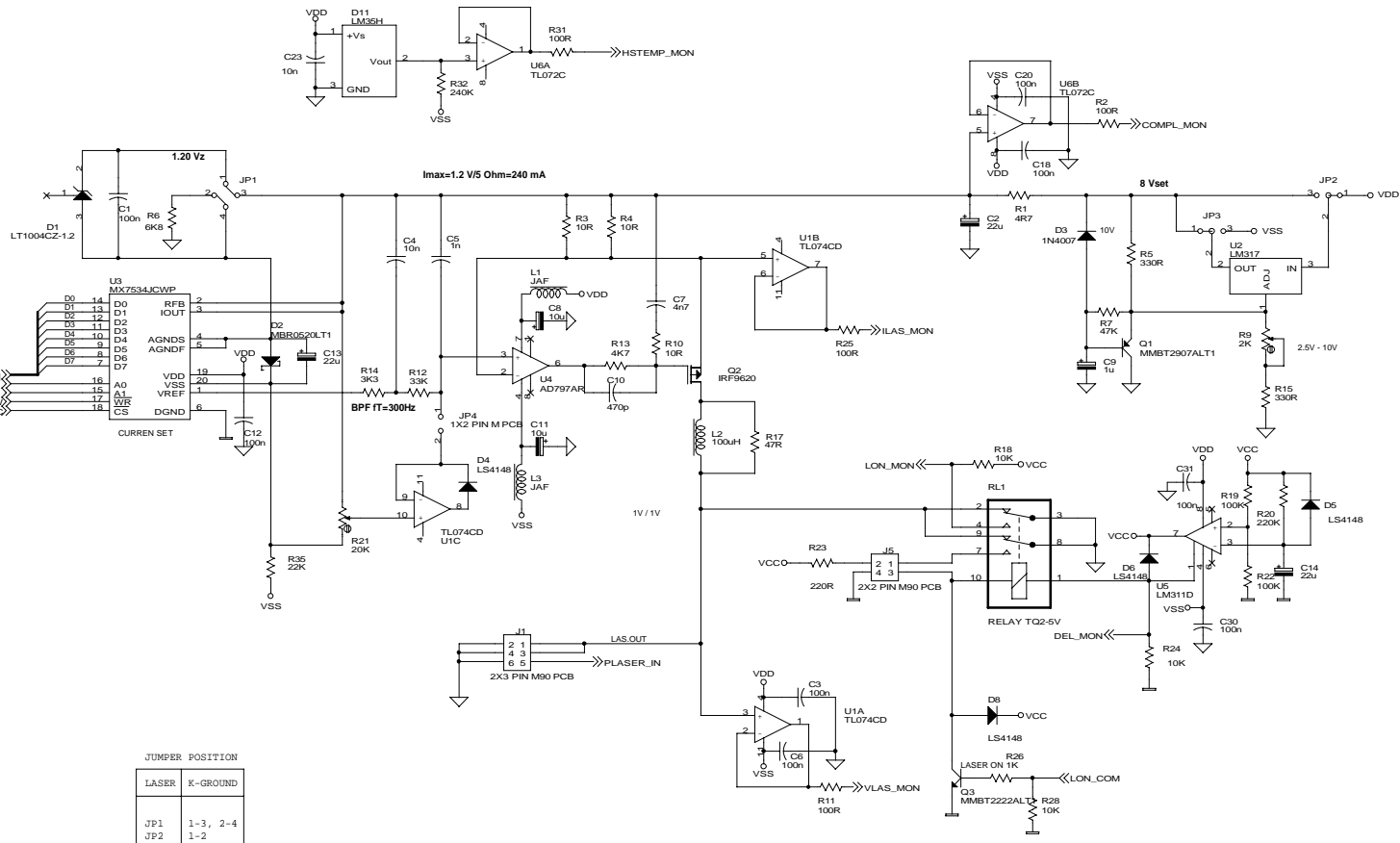

JUMPER POSITION

LASER	K-GROUND
JP1	1-3, 2-4
JP2	1-2
JP3	1-2

LENS -UNIVERSITA' DI FIRENZE-	
LARGO E.FERMI, 2 50125 FIRENZE	
File	LASER DRIVER
Size	Document Number LASERDRV_2.SCH
Date:	Friday, March 23, 2007 Sheet 1 of 2

LENS -UNIVERSITA' DI FIRENZE-
 LARGO E.FERMI, 2 50125 FIRENZE

Bill Of Materials March 23,2007 10:55:35 Page1

Item Ref	Quantity	Reference	Description	Part	Part Value	Supplier
1 264-4416	20	C1,C3,C6,C12,C15,C18,C20, C27,C28,C29,C30,C31,C32, C33,C34,C35,C36,C37,C38, C39	Cond. Cer.	50V	100n	RS
2 4636	6	C2,C13,C14,C16,C17,C19	Cond. Tant.	25V	22u	RS 262-
3	4	C4,C23,C24,C40	Cond. Cer.	50V	10n	RS 298-9309
4	1	C5	Cond. Cer.	50V	1n	RS 237-6961
5	1	C7	Cond. Cer.	50V	4n7	RS 237-7015
6	2	C8,C11	Cond. Tant.	25V	10u	RS 262-4658
7	1	C9	Cond. Tant.	25V	1u	RS 262-4670
8	1	C10	Cond. Cer.	50V	470p	RS 264-4345
9	2	C21,C26	Cond. Cer.	50V	100p	RS 298-9258
10	2	C22,C25	Cond. Tant.	25V	4u7	RS 262-4428
11	1	D1	Voltage Reference	LT1004CZ-1.2		RS 429-243
12	1	D2	Schottky Diode	MBR0520LT1		Farnell 708-136
13	1	D3	Si Diode	1N4007		RS 261-980
14 3690	6	D4,D5,D6,D8,D9,D10	Si Diode	LS4148		RS 443-
15	1	D11	Temp. Sensor	LM35H		DISCO SRL
16	1	JP1	Connettore	2X2		PIN M PCB
17	2	JP3,JP2	Connettore	1X3		PIN M PCB
18	1	JP4	Connettore	1X2		PIN M PCB
19	1	JP5	Connettore	3X6		PIN M PCB
20	1	J1	Connettore	2X3		PIN M90 PCB
21	2	J6,J2	Connettore	2X4		PIN M90 PCB Disco 5/5580
22	1	J3	Connettore	1X7		PIN M PCB
23	1	J4	Connettore	2X3		PIN M90 PCB
24	1	J5	Connettore	2X2		PIN M90 PCB
25	5	L1,L3,L4,L5,L6	Induttanza	JAF		RS 233-5077
26	1	L2	Induttanza	100uH		RS 191-0598
27 359-956	1	PC104_HEADER_J1P1	Connettore	CON		PC/104-64 Farnell
28 359-907	1	PC104_HEADER_J2P2	Connettore	CON		PC/104-32 Farnell
29	1	Q1	Transistor	MMBT2907ALT1		RS 112-6226
30	1	Q2	Transistor	IRF9620		RS 245-1400
31	1	Q3	Transistor	MMBT2222ALT1		RS 112-6181
32	1	Q4	Transistor	MMBT2222ALT		RS 112-6181
33	1	RL1	Relay RELAY	TQ2-5V		RS 113-8825
34	1	R1	Res. 0.5W	5% 4R7		
35	5	R2,R8,R11,R25,R31	Res. 0.25W	1% 100R		RS 223-0297
36	2	R3,R4	Res. 0.3W	0.1% 10R		Vishay SMRD
37	2	R5,R15	Res. 0.25W	1% 330R		RS 223-0354
38	1	R6	Res. 0.25W	1% 6K8		RS 223-0540
39	2	R29,R7	Res. 0.25W	1% 47K		RS 223-0641
40	1	R9	Trim. Vert.	10G 2K		Farnell 321-8090
41	1	R10	Res. 0.25W	1% 10R		RS 223-0152
42	1	R12	Res. 0.25W	1% 33K		RS 223-0629
43	1	R13	Res. 0.25W	1% 4K7		RS 223-0528

44	1	R14	Res. 0.25W 1%	3K3	RS 223-0499	
45	5	R16,R18,R24,R27,R28	Res. 0.25W 1%		10K	RS 223-0562
46	1	R17	Res. 0.25W 1%	47R	RS 223-0253	
47	2	R22,R19	Res. 0.25W 1%		100K	RS 223-0691
48	1	R20	Res. 0.25W 1%	220K	RS 223-0742	
49	1	R21	Trim. Vert. 10G	20K	Farnell	321-8211
50	1	R23	Res. 0.25W 1%	220R	RS 223-0332	
51	1	R26	Res. 0.25W 1%	1K	RS 223-0427	
52	1	R30	Res. 0.25W 1%	2K	Farnell	321-8090
53	1	R32	Res. 0.25W 1%	240K	Farnell	321-8340
54	1	R33	Res. 0.25W 1%	0R (JUMPERED)		
55	1	R34	Res. 0.25W 1%	xxx		
56	1	R35	Res. 0.25W 1%	22K	RS 223-0607	
57	1	U1	Circ. Integr.	TL074CD	RS 857-929	
58	1	U2	Circ. Integr.	LM317	RS 641-702	
59	1	U3	Circ. Integr.	MX7534JCWP	EC_MAXIM	
60	1	U4	Circ. Integr.	AD797AR	RS 184-1026 /	
Farnell		796-633				
61	1	U5	Circ. Integr.	LM311D	RS 858-398 /	Farnell
115-782						
62	1	U6	Circ. Integr.	TL072C	RS436-3254 /	Farnell
401-134						
63	1	U8	Circ. Integr.	74HC245	RS 113-0174	
64	1	U9	Circ. Integr.	ispLSI2064VE-200LT44	RS 414-	
2158						
65	1	U11	Circ. Integr.	MAX197ACWI	EC_MAXIM	